



GUYANA CIVIL AVIATION AUTHORITY

Colgrain House
205 Camp Street
North Cummingsburg
Georgetown
GUYANA

TEL. NOs: (592) 225 6822,
225 0778, 227 8111
FAX: (592) 225 6800
E-mail: director-general@gcaa-gy.org

GCAA
ADVISORY CIRCULAR

AIRWORTHINESS
AC NO: GCAA AC/AIR-019

SUBJECT	AIRCRAFT WELDING APPROVALS AND QUALIFICATIONS	DATE INITIATED:	16-03-2015
		INITIATED BY:	DASR

1. Purpose

The purpose of this AC is to provide information on the application for the initial issue and renewal of an aircraft welding authorisation under GARs Part 6.

2. General Information/Cancellation

- a. This Advisory Circular GCAA AC/AIR-019 is a complete re-issue on the subject and cancels Airworthiness AC # 19 dated 26/11/2007. The effective date of this AC is April 1, 2015.
- b. Welding is a specialized skill required in the performance of maintenance of aircraft and aeronautical products under the supervision of Airframe and Engine license categories. This AC provides guidance to Approved Maintenance Organisations for the issuance of authorisation to perform welding of aircraft and aeronautical products for carrying out welding in the course of maintenance of Guyana aircraft and aeronautical product.

3. Relevant References

Guyana Aviation Requirements (GARs) Part 6 - "**Approved Maintenance Organisation**".

4. Contact Information

Director General of Civil Aviation
@ Address and contact information shown in the header, or
Director, Aviation Safety Regulation
Phone: (592) 225 0778, Ext. 104
E-mail: dasr@gcaa-gy.org

PART: A GENERAL

5. Welding Authorisation Background

- a. Welding is a class of maintenance for which a license is not covered by the Guyana Civil Aviation (Air Navigation) Regulations (GCARs) or the GARs with regards to personnel licensing structure of aircraft maintenance engineers. The performance of welding work on a Guyana registered aircraft or aeronautical product can only be done under the authorisation system of an Approved Maintenance Organisation (AMO).
- b. A holder of an aircraft welding authorisation from an AMO may only carry out those types of welding processes that are specified in the welding authorisation document.
- c. The holder of a welding authorisation is limited to repair and maintenance only of aeronautical products and is not authorized to fabricate parts for storage or for third parties.

6. Duration of Welding Authorities

Aircraft welding authorisations may be granted or renewed by an Approved Maintenance Organisation for a period of not more than two (2) years.

PART: B
GRANT OF WELDING AUTHORISATION

7. Person Eligible for Welding Authorisation

- a. An applicant for a welding authorisation under GARs Part 6 must satisfy the training and competency requirements set out in this AC.
- b. Person's eligibility for a welding authorisation under GARs Part 6 includes those who have:
 - (1) Successfully completed a recognized course of practical and theoretical training in the particular type of manual welding and parent metal group qualification sought; and
 - (2) Passed the applicable welding test(s) set out in Appendix A in accordance with the appropriate welding syllabus.

8. Application for Welding Authorisation

- a. An application for the grant, extension or renewal of an aircraft welding authorisation may be made by completing the relevant authorisation application form within the Approved Maintenance Organisation.
- b. The application as a minimum should contain:
 - (1) Details of welding qualification, training and work history;
 - (2) Certification records from a recognized welding test facility as applicable indicating submitted weld samples were satisfactory; and
 - (3) Records of any previously held welding authorisation.

9. Renewal of Welding Authorisation

- a. The procedure for renewing a welding authorisation is as follows:
 - (1) In order to renew an aircraft welding authorisation, an applicant must successfully complete the aircraft welding examinations specified in Appendix A within the 3 months preceding the expiry date of the authorisation.
 - (2) An AMO approved to conduct welding of aircraft or aeronautical products will arrange for the welder to prepare the appropriate test sample or samples. A representative of the quality department of the AMO shall supervise the preparation of weld test pieces for submission to a recognized testing organisation for examination.
 - (3) A holder of an aircraft welding authorisation endorsed with a braze welding permission must successfully complete a braze weld test procedure in accordance with Appendix A.

10. Recognition of Equivalent Welding Qualifications

- a. An AMO may recognize the following welding qualifications:
 - (1) American Welding Society (AWS) certification;
 - (2) Canadian Welding Bureau;
 - (3) European Committee for Standardization;
 - (4) Civil Aviation Authority UK (BCAR Subsection A8-10 - Approval of Welders);
 - (5) A welder certification issued within the preceding two (2) years by a Federal Aviation Administration approved maintenance organisation whose approval includes welding of aircraft; and
 - (6) An equivalent recognized welding certification authority.

10. Recognition of Equivalent Welding Qualifications, Cont'd

- b. An AMO may consider equivalent welding qualifications for the issue of an aircraft welding authorisation without requiring the applicant to undergo the welding training and examination where:
 - (1) the equivalent qualifications are current/valid at the time of application; and
 - (2) the applicant can provide appropriate supporting documentary evidence, such as a qualification document and authenticated associated employment records.
- c. In the case of employer-issued certifications, an AMO shall be required to provide documentary evidence to the GCAA that the certification was assessed and issued in accordance with an appropriate standard. Acceptable standards are listed in Appendix B.
- d. An aircraft welding authorisation issued by an AMO under these provisions will take effect from the date of approval and may be issued for a maximum period of two (2) years from the date of last issue of the welding qualification document that is being recognized.

PART: C

RESPONSIBILITIES OF AN AIRCRAFT WELDING AUTHORISATION HOLDER

11. Welding Authorisation – Maintenance Performance Scope

- a. The holder of an aircraft welding authorisation can only carry out the kind of welding that is specified on the aircraft welding authorisation and only in accordance with approved maintenance data and procedures approved by the manufacturer or State of Design for the aeronautical product.
- b. The welder shall maintain proficiency in accordance with the program set out in the AMO MPM and must perform at least one welding task every six months for every authorisation he holds.
- c. Where a welder cannot meet the requirement in "b" above on an aircraft or aeronautical product, in order to maintain proficiency, the welder may perform at least one sample welding task to the satisfaction of the AMO for each authorisation he holds.

12. Certification

- a. Under the requirements of GARs Part 6 the holder of an aircraft welding authorisation must sign for completion of the welding task carried out in the documents kept for recording such maintenance.
- b. Separate certification for the completion of maintenance on an aircraft must be made by an appropriately rated Licensed Aircraft Maintenance Engineer (LAME). The LAME certification signifies that the maintenance (manual welding task) has been carried out in accordance with approved maintenance data by a suitably qualified person and that the LAME is satisfied that the aircraft is fit for return to service.

PART: D

WELDERS COMPETENCY

13. Competency

- a. The GCAA may at any time require a welding authorisation holder to undergo welding tests in order to ascertain the person's competency as a welder.
- b. Where a satisfactory standard is not achieved the authorisation may be suspended wholly or in part by the AMO until such time as the welding authorisation holder successfully passes the appropriate weld tests.

14. The Conduct of Aircraft Welding Examinations

- a. **Eligibility.** An organisation conducting aircraft welding examinations shall have staff with demonstrated understanding and working knowledge of the welding examination requirements, the associated civil aviation regulatory requirements, responsibilities of a welding authority holder; and:
 - (1) have experience as a welding lecturer at a recognized welding training organisation, e.g. CARIRI, MIC, UTT, or an approved training school, or
 - (2) have experience as a welding supervisor in an approved welding organisation, or
 - (3) Hold other appropriate engineering qualifications and background acceptable to the GCAA.
- b. **Recognition Process.** The requesting AMO should prepare a written application and send it together with the prescribed fees to the GCAA. The application should include:
 - (1) details of the person to be examined, inclusive of qualifications and experience;
 - (2) details of facilities, testing equipment and national approvals or certification held; and
 - (3) any documentary evidence necessary to support weld examination capability.

The GCAA will assess the proposed examination organisation's capabilities to conduct the aircraft welding examinations by taking into account the application details, the facilities and equipment available and the assurance that you will continue to receive all information necessary for the conduct of the welding examinations.

- c. **Recognition Period.** Once the examining organisation is accepted, the recognition shall be considered valid provided it:
 - (1) continues to exercise its capability to examine welds and the national approval or certification held is not expired and remains valid;
 - (2) continues satisfactory performance of the functions and activities authorized; maintain a system for the retention and control of records and documentation relating to the examination conducted (a log of welds); and
 - (3) notifies the requesting organisation as soon as practicable on a change of name or address.
- d. **Organisations Conducting an Aircraft Welding Examination.** Aircraft welding examinations are conducted in accordance with conditions specified in the attached Appendices, the relevant welding standard and this AC. The following is representative of the minimum requirements for the conduct of welding examinations - when conducting aircraft welding examinations the examiner should ensure:
 - (1) the applicant has a demonstrated knowledge of a welder's responsibility and limitations as the holder of an aircraft welding authority, and has adequate knowledge of welding terms and definitions, the interpretation of drawings, joint preparation and welding defects and thermal stress;

14. The Conduct of Aircraft Welding Examinations, Cont'd

- (2) each aircraft welding examination is carried out in accordance with the specifications set out in this AC;
- (3) the welding positions and metal groups are as specified and the procedures and consumable materials are representative of those used in production;
- (4) the metal selected satisfies a degree of difficulty similar to the welding characteristics of the production welding task, any pre and/or post weld heat treatment, if required, is performed in a similar manner to that required or production welds represented by the weld samples; and
- (5) the welds are not dressed or sand-blasted after welding, and any weld residue (flux, slag) is removed in the normal manner from the weld samples.

15. Weld Identification and Documentation

- a. The test weld samples must be uniquely identified by stamp, etch or permanent marks to match the applicant. This can be accomplished by a reference number and the welding position codes (as applicable) being placed on each welding sample.
- b. The requesting organisation should then complete the "*Request for Weld Test Form*" or letter and send this together with the welding samples to the appropriate weld testing agency for weld assessment.
- c. After receiving the weld testing agency's assessment report, this must be kept on file for the applicant as evidence of satisfactory accomplishment of the test welds. These along with any documentation and records of weld authority granted or renewed must be available for inspection by the GCAA.

16. Failed Examination Action

Where applicants fail an aircraft welding examination, they may make arrangements to attempt a further examination without penalty. However, if they again fail the re-examination, the GCAA recommends that they should complete some form of remedial training on the type of welding process/metal group before they are permitted to re-attempt the examination.

Approved By:



Zulficar Mohamed
Director General of Civil Aviation
Guyana Civil Aviation Authority

APPENDICES

CONTENTS

SUBJECT	PAGE
APPENDIX A - WELDING SYLLABUS PUBLICATION AIRCRAFT WELDING EXAMINATIONS	9-30
A1 General	9
A2 Types Of Manual Welding	9
A3 Parent Metal Groups	9
A4 PART 1 - AIRCRAFT WELDING EXAMINATIONS	10
A4.1 Types of Aircraft Welding Examinations	10
A4.2 Examinations Required For Initial Grant of an Aircraft Welding Authorisation	10
A4.3 Examinations Required For Renewal of an Aircraft Welding Authorisation	10
A4.4 Welding Authorisation Renewals and Additions – General Information	11
A4.5 Examination Failure	12
A4.6 Parent Metal Thickness Limitation/Conditions	12
A4.7 Welding Identification and Welding Position Code	12
A4.8 Examples of Examination Combinations and Conditions	12
A4.9 Aircraft Welding Examination No. 1 – Joint 1	15
A4.10 Aircraft Welding Examination No. 2 – Joint 2	16
A4.11 Aircraft Welding Examination No. 3 – Joint 3	17
A4.12 Aircraft Welding Examination No. 4 – Joint 4	18
A4.13 Aircraft Welding Examination No. 5 – Joint 5	20
A5 PART 2 - EXAMINATION ASSESSMENT CONSIDERATIONS	21
A5.1 Assessment Standard	21
A5.2 Braze Welding Assessment	21
A5.3 Visual Examination	21
A5.4 Tensile Tests	22
A5.5 Bend Test	23
A5.6 Metallographic Examination	24
A5.7 Weld Assessments — Figures 1	25
A5.8 Weld Assessments — Figures 2	26
A5.9 Weld Assessments — Figures 3	26
A5.10 Weld Assessments — Figures 4	27
A5.11 Weld Assessments — Figures 5	27
A5.12 Weld Assessments — Figures 6	28
A5.13 Weld Assessments — Figures 7	28
A5.14 Weld Assessments — Figures 8	29
A5.15 Weld Assessments — Figures 8	29
A5.16 Weld Assessments — Figures 9	29
A5.17 Weld Assessments — Figures 10	30
APPENDIX B – ACCEPTABLE STANDARDS	31

APPENDIX: A

WELDING SYLLABUS PUBLICATION AIRCRAFT WELDING EXAMINATIONS

A1

GENERAL

This Appendix A sets out the requirements necessary for the preparation and assessment of aircraft welding examinations required by GARs Part 6.

A2

TYPES OF MANUAL WELDING

Satisfactory completion of aircraft welding examinations, made under one of the following types of manual welding processes, qualifies the welder with respect to that type of welding.

Difficulty rating:

- Type 1 - Gas welding.
- Type 2 - Braze welding. [Note limitations apply].
- Type 3 - Manual Metal Arc Welding.
- Type 4 - Gas Tungsten Arc Welding (GTAW - TIG).
- Type 5 - Gas Metal Arc Welding (GMAW - MIG).
- Type 6 - Plasma Arc Welding (PAW).

A3

PARENT METAL GROUPS

The parent metal groups for which qualifications may be obtained are:

- Group 1 - Aluminum Alloys.
- Group 2 - Magnesium Alloys.
- Group 3 - Carbon Steels and Low Alloy Steels.
- Group 4 - Corrosion and Heat Resisting Steels.
- Group 5 - Nickel Alloys.
- Group 6 - Copper based Alloys.
- Group 7 - Titanium Alloy

PART: 1
AIRCRAFT WELDING EXAMINATION

A4.1 TYPES OF AIRCRAFT WELDING EXAMINATIONS

Dependent on the welding qualification sought, the aircraft welding examinations required to obtain qualifications are to be prepared as follows:

- Joint No. 1 - Sheet to sheet butt weld as specified in Diagram 1.
- Joint No. 2 - Tube to sheet fillet weld as specified in Diagram 2.
- Joint No. 3 - Sheet to sheet fillet weld as specified in Diagram 3.
- Joint No. 4 - Tube to tube test weld as specified in Diagram 4.
- Joint No. 5 - An aircraft part typical of the most difficult to be welded in production/repair by the applicant, e.g. repair/rebuild of engine nozzle guide vane; repair of gas turbine engine flame tube or repairs to component castings etc.

Note: *A welding test joint which simulates the Joint No. 5 part may be prepared by the applicant at the discretion of the person conducting the aircraft welding examination. Where a simulated joint is prepared, the applicant must use the same materials, equipment, process, joint configuration, welding technique and maintenance data/specifications as that used for the production or repair part.*

**A4.2 EXAMINATIONS REQUIRED FOR INITIAL GRANT
OF AN AIRCRAFT WELDING AUTHORISATION**

- a. An applicant for the grant of an aircraft welding authorisation must satisfactorily complete at least one of the aircraft welding examinations set out in this publication. The aircraft welding examination must be completed in each of the types of manual welding and parent metal groups to which the application relates and is relevant to the conditions of the authorisation sought.
- b. Applicants for a braze welding type of manual welding qualification must satisfactorily complete at least the aircraft welding examination Joint No. 2 in the parent metal group to which the application relates.
- c. Braze welding is restricted to tube-to-sheet Joint No. 2 and the type of weld joint prepared as Joint No. 5. There is no "unrestricted" qualification or "restricted to exclude tubular parts" qualification permitted for braze welding. "Tubular part", means a part of a primary structure not exceeding approximately 50 mm in diameter.

**A4.3 EXAMINATIONS REQUIRED FOR RENEWAL
OF AN AIRCRAFT WELDING AUTHORISATION**

- a. The holder of an aircraft welding authorisation seeking renewal of the authority must, within the three (3) month application period, satisfactorily complete aircraft welding examinations, as set out in this publication.
- b. Failure to satisfactorily complete the necessary renewal welding examinations before the expiry of an aircraft welding authorisation will invalidate the authorisations held.

A4.4 WELDING AUTHORISATION RENEWALS AND ADDITIONS – GENERAL INFORMATION

A4.4.1 Renewal Requirements for Holders of an Aircraft Welding Authorisation Not Employed as a Full Time Aircraft Welder in an Approved Maintenance Organisation

The holder of an aircraft welding authorisation who has **not** been employed in an approved organisation as a full time aircraft welder, who is seeking renewal of the authority must, within the three (3) month application period, satisfactorily complete:

- (1) one Joint No. 1 in each parent metal group endorsement in any arc-welding process;
- (2) one Joint No. 1 in each parent metal group endorsement in the gas-welding process (if applicable); and
- (3) where an "unrestricted" endorsement is held, one Joint No. 4 in the most technically difficult welding type and metal group qualification held.

A4.4.2 Renewal Requirements for Holders of an Aircraft Welding Authorisation Employed as a Full Time Aircraft Welder in an Approved Organisation

- a. The holder of an aircraft welding authorisation employed as a full-time welder in an approved organisation is required to successfully complete the same aircraft welding examinations as that for an independent aircraft welding authorisation holder.
- b. However, the employer (Certificate of Approval holder) may implement and document procedures in the organisation's quality control system/procedures manual whereby similar (renewal) welding examinations are carried out over the duration of the welding authorisation's two (2) year validity period and assessed at a recognized testing facility.
- c. Such tests may form part of the employer procedures but are to be conducted within the 3 month renewal application period.

A4.4.3 Renewal Requirements for Holders of Aircraft Welding Authorisation Endorsed with Braze Welding

All holders of aircraft welding authority endorsed with Type 2 - Braze Welding qualifications must, within the three (3) month application period, satisfactorily complete a welding examination in accordance with a listed in Appendix B.

A4.4.4 Addition of a Type of Manual Welding

Where the holder of an aircraft welding authorisation is seeking to have a type of manual welding (other than Type 2 - Braze Welding) added to the authority, the holder must satisfactorily complete at least one of the aircraft welding examinations, set out in this publication, in the type of manual welding to which the application relates in any parent metal group.

A4.4.5 Addition of a Parent Metal Group

Where the holder of an aircraft welding authorisation is seeking to have a parent metal group added to the authority, the holder must satisfactorily complete at least one of the aircraft welding examinations, set out in this publication, in the parent metal group to which the application relates in any type of manual welding.

A4.4.6 Addition of Braze Welding

If the holder of an aircraft welding authorisation is seeking to have Type 2 - Braze Welding added to the authority, the holder must satisfactorily complete a braze welding test in accordance with a standard listed in Appendix B.

A4.5 EXAMINATION FAILURE

- a. Where an applicant fails a welding examination for the initial issue, renewal or additional qualifications of a welding authorisation, the applicant may submit a further welding examination sample for assessment.
- b. If the applicant then fails the re-examination, it is recommended that the applicant complete remedial practical and theoretical training on the type of manual welding and parent metal group and demonstrate welding practice to the person conducting the welding examination prior to further examination.

A4.6 PARENT METAL THICKNESS LIMITATION/CONDITIONS

- a. The welding examinations — Joints No. 1, No. 2, No. 3 and No. 4 specify that the weld must be carried out on a pre-determined representative parent metal thickness for the particular welding process (gas) or (arc).
- b. Welders complying with the examination metal thickness specifications are authorized to carry out manual welding (using the particular process) on parent metals of any thickness. There will be no parent metal thickness limitation or condition endorsement made on the welding authorisation.
- c. Welders who carry out welding examinations using parent metals of a greater thickness than that specified for the welding examination will be authorized to carry out welds on the parent metal of that thickness or greater. The welding authorisation will be endorsed with a parent metal thickness condition e.g., if the welding examination specifies that the sheets to be arc welded must be 1.2 mm thick and the welder uses sheets of 1.5 mm thick, then the parent metal thickness condition endorsed on the welding authorisation will limit the welder to only carrying out welds on metals of 1.5 mm thickness or greater.

A4.7 WELDING IDENTIFICATION AND WELDING POSITION CODE

On completion of the welding examination, the person conducting the examination must stamp, etch or permanently mark each welding examination sample with the applicant's reference number and the appropriate welding position code letter, as follows:

- **F - Flat** (fillet or butt) - where the face of the weld is approximately horizontal;
- **H - Horizontal** (fillet or butt) - where the line of weld root is approximately horizontal;
- **OH** - Overhead (fillet or butt) - where the weld is performed from the under-side of the joint;
- **HV** (Multiple Position [fillet only]) - where the axis of the tube is approximately horizontal and the tube is not rotated during welding; or
- **V** (Vertical [fillet or butt]), where the line of the weld root is approximately vertical.

A4.8 EXAMPLES OF EXAMINATION COMBINATIONS AND CONDITIONS

- a. An aircraft welding authorisation will be granted subject to the qualification conditions or restrictions determined by the type and number of welding examination combinations selected and satisfactorily completed by the welder.
- b. Examples of the conditions imposed when particular aircraft welding examination combinations have been successfully completed are given below and apply to both the initial issue and additional qualification requirements for an aircraft welding authorisation:

A4.8 EXAMPLES OF EXAMINATION COMBINATIONS AND CONDITIONS, CONT'D

EXAMPLE: 1

WELDING EXAMINATION CARRIED OUT	
Joint No. 1	
Condition Entered on Welding authorisation —for each type of manual welding and parent metal group.	
"Restricted to Butt welds of 'X' mm thick sheets"	

- c. This Example 1 is intended to show the flexibility of welding examination selection for welding authorisation whereby an applicant only requires one welding examination qualification. The satisfactory completion of Joint No. 1 will authorize the welder to carry out manual welding 'butt welds' (using a particular process) on sheets of a specified thickness (for a particular parent metal). Similarly, if, for example, a Joint No. 3 is selected and satisfactorily completed, the form of condition entered on the authority may read "Restricted to fillet welds of sheets 'x' mm thickness" (for the particular process/metal group).

EXAMPLE: 2

WELDING EXAMINATION CARRIED OUT	
Joint No. 2	Joint No. 5
Condition Entered on Welding authorisation —for each parent metal group.	
"Braze Welding only - Restricted to particular parts or types of parts" (statement may include description of part(s) or approved procedures reference).	

- d. With respect to Braze Welding – braze welding qualification is restricted for tube to sheet Joint No. 2 and the type of the weld prepared as Joint No. 5. There is no "Unrestricted" qualification or "Restricted to exclude tubular parts" qualification permitted for braze welding.

EXAMPLE: 3

WELDING EXAMINATION CARRIED OUT	
Joint No. 1	Joint No. 5
Condition Entered on Welding authorisation - for each type of manual welding and parent metal group.	
"Restricted to particular parts or types of parts" (statement may include description of part(s) or approved procedures reference).	

- e. The annotation "Restricted to particular parts or type of parts", requiring Joints No. 1 and 5, applies where the only welds to be carried out are restricted to a particular joint configuration on a specific part or types of parts, e.g., repair/rebuild of engine nozzle guide vanes, or repair of gas turbine engine flame tube or repairs to component castings, etc. This may also apply where welds are carried out repetitively on a production line basis in accordance with particular procedural data.
- f. The holder is only authorized to carry out manual welding of the particular part or type of parts described in the welding authorisation (e.g., butt joints in flame tubes of (type) engines, or edge welds on nozzle guide vane support Part No. ..., etc.).

A4.8 EXAMPLES OF EXAMINATION COMBINATIONS AND CONDITIONS, CONT'D

- g. The welding carried out must be as specified in the approved maintenance data for the parent metal group and type of manual welding for which the "Restricted to part" annotation is granted.

EXAMPLE: 4

WELDING EXAMINATION CARRIED OUT		
Joint No. 1	Joint No. 3	Joint No. 5
Condition Entered on Welding authorisation - for each type of manual welding and parent metal group.		
"Restricted to exclude tubular parts"		

- h. The annotation "Restricted to exclude tubular parts", requiring Joints No. 1, 3 and 5 is intended to make provision for applications for metal groups other than aluminum or steel, which are generally not used in tubular form in aircraft primary structure or are not generally available in tubular form. e.g., magnesium, nickel or titanium (as a tubular part is part of a primary aircraft structure not exceeding approximately 50 millimeters in diameter, then an exhaust manifold is not considered a tubular part since it is not primary structure).
- i. The holder is authorized to carry out manual welding of any part (e.g., flat, horizontal and overhead butt welds and fillet welds for sheet-to-sheet), except for tubular parts, where welding is specified in approved maintenance data for the parent metal group and type of manual welding for which the "Restricted" annotation is granted.

EXAMPLE: 5

WELDING EXAMINATION CARRIED OUT		
Joint No. 1	Joint No. 2	Joint No. 4
Condition Entered on Welding authorisation - for each type of manual welding and parent metal group.		
"Unrestricted" or "Nil"		

- j. The "Unrestricted or Nil" annotation, requiring Joints No. 1, 2 and 4 is granted on the basis that the selection of joints is considered sufficiently searching of welding ability in the majority of cases (e.g., flat, horizontal, overhead, vertical and multi-position butt welds [sheet-to-sheet], fillet welds [sheet-to-sheet] [sheet-to-tube] and fillet and butt welds [tubular parts]).
- k. It is intended to apply primarily to aluminum and steel metal groups and where structural tubing is in common use. Where more difficult welds are to be carried out to satisfy production, additional Joint No. 5 examination may be required.
- l. The welder is authorized to carry out manual welds of any part where welding is specified in approved maintenance data, without restriction for the parent metal group and type of manual welding for which the "Unrestricted or Nil" annotation is granted.

A4.9 AIRCRAFT WELDING EXAMINATION NO. 1 – JOINT 1

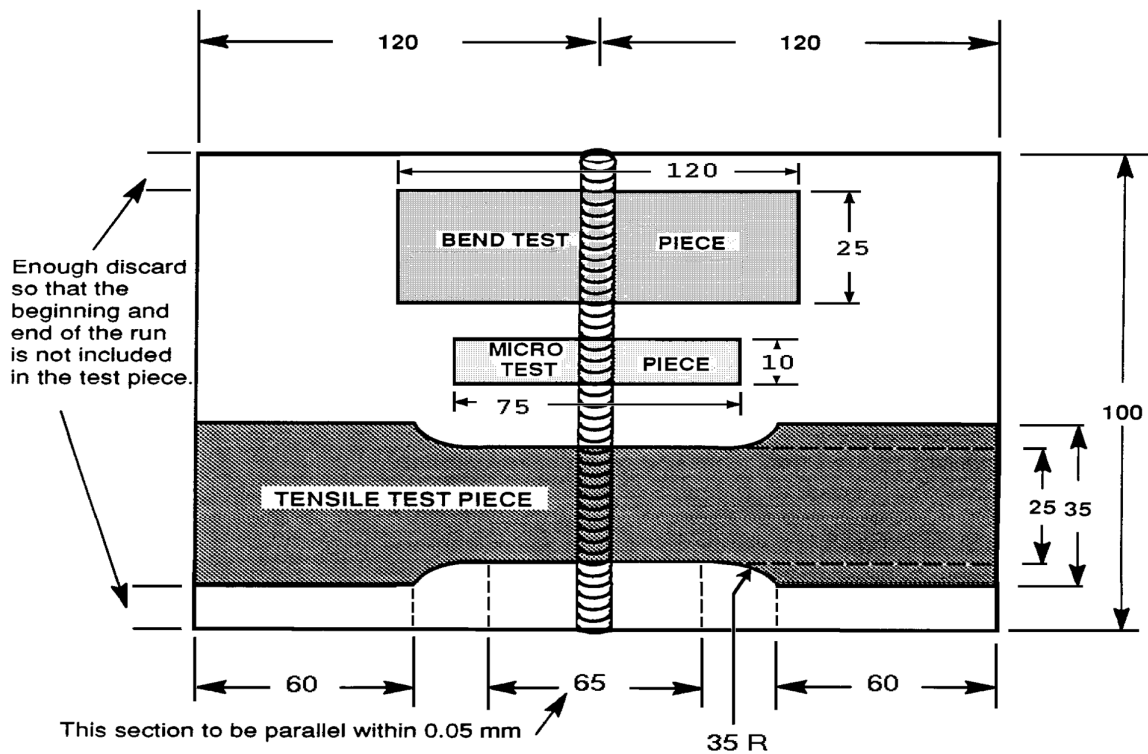

Diagram 1 – Joint No 1 – Sheet to Sheet Butt Weld

Weld for Aircraft Welding Examination No. 1

- a. For the purposes of undertaking the aircraft welding examination No. 1, a person must carry out a Joint No. 1 - sheet to sheet butt weld in accordance with the specifications set out in Diagram 1.
- b. All measurements are nominal and in millimeters (mm).
- c. The examinations must be carried out using parent metals of the same alloy type or grade procured to the applicable specifications referenced in the production procedure/maintenance data.
- d. For oxy-acetylene (gas), GTAW (TIG) and MTAW (MIG) welding processes, examination metal thickness of sheets is 1.6 mm thick (this will include material of 0.063 inch thickness).
- e. For other arc welding processes, examination metal thickness of sheets is 2.5 mm to 2.6 mm thick (this includes sheet of 0.100 inch thickness).
- f. If sheets of other thicknesses are used, the thicknesses of the sheets should be kept in these proportions. (**Note:** Authorisation will be subject to thickness conditions.)
- g. Tack welds may be made from any position but shall be incorporated into the completed weld.
- h. Welding position - flat.
- i. The weld shall be performed by welding from one side only using correct filler rod, flux or shielding gas as applicable.

A4.9 AIRCRAFT WELDING EXAMINATION NO. 1 – JOINT 1, CONT'D

- j. The sheets to be welded shall be supported so that they do not contact the bench or other material that will form a backing bar in the welded joint.
- k. Completed welds may be cleaned by wire brush, but must not be dressed, hammered or sand blasted (light tapping with a hammer to remove scale deposits is not regarded as a dressing operation).
- l. Weld residue (flux, slag) shall be removed from the weld in the usual way.
- m. Be aware of any grain direction in the material which may compromise the bend test.

A4.10 AIRCRAFT WELDING EXAMINATION NO. 2 – JOINT 2

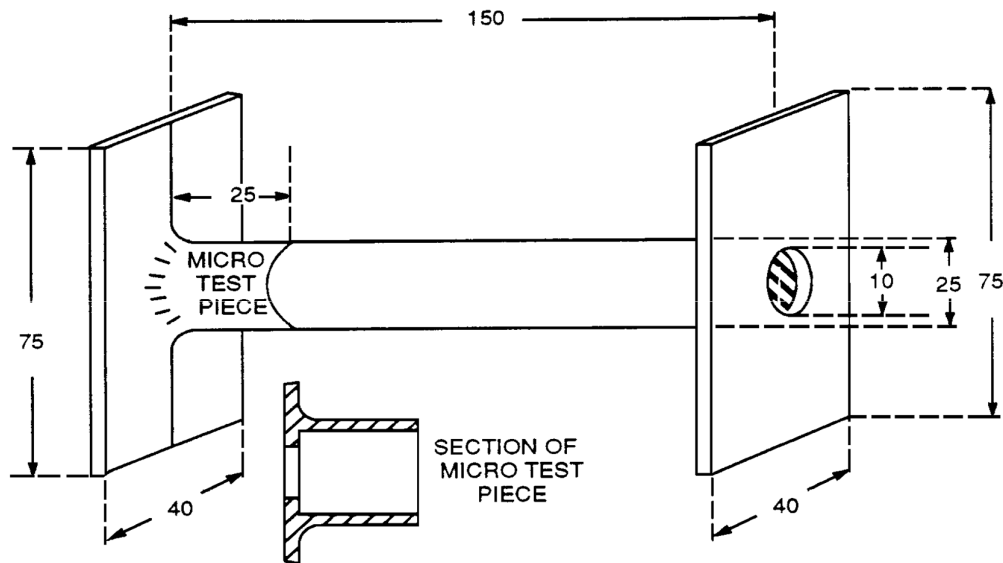

Diagram 2 – Joint No 2 Sheet to Tube Fillet Weld

Weld for Aircraft Welding Examination No. 2

- a. For the purposes of undertaking the aircraft welding examination No. 2, a person must carry out a Joint No. 2 - sheet to tube fillet weld in accordance with the specifications set out in diagram No. 2.
- b. All measurements are nominal and in millimeters (mm).
- c. The examinations must be carried out using parent metals of the same alloy type or grade procured to the applicable specifications referenced in the production procedure/maintenance data.
- d. For oxy-acetylene (gas), GMAW (MIG) and GTAW (TIG) welding processes, examination metal thickness for tube is 0.9 mm wall thickness and end plates of 1.6 mm thick.
- e. For other arc welding processes, examination metal thickness for tube is 1.6 mm to 1.65 mm (this includes 0.065 inch) wall thickness and end plates of 2.5 mm to 2.6 mm thick (includes 0.100 inch sheet).

A4.10 AIRCRAFT WELDING EXAMINATION NO. 2 – JOINT 2, CONT'D

- f. If tubes and end plates of other thicknesses are used, the thicknesses should be kept in these proportions. (Note: Authorisation will be subject to thickness conditions). Where a greater thickness material is used there must be two nominal gauge sizes difference between the tube and end plate.
- g. Centre of end plates to be drilled with 10 mm diameter hole prior to welding.
- h. End plates may be positioned by tack welds.
- i. The first weld shall be completed by working around the tube with the end plate horizontal (flat) on the work surface and the tube in the vertical position.
- j. The second weld shall be completed by working under and over the tube with the tube in the horizontal position (as depicted in Diagram 2) and not moved during the process of completing the weld. (Note: the micro test piece will be taken from the second weld area).
- k. Completed welds may be cleaned by wire brush, but must not be dressed, hammered or sand-blasted (light tapping with a hammer to remove scale deposits is acceptable and is not regarded as a dressing operation).
- l. Weld residue (flux, slag) shall be removed from the weld in the usual way.

A4.11 AIRCRAFT WELDING EXAMINATION NO. 3 – JOINT 3

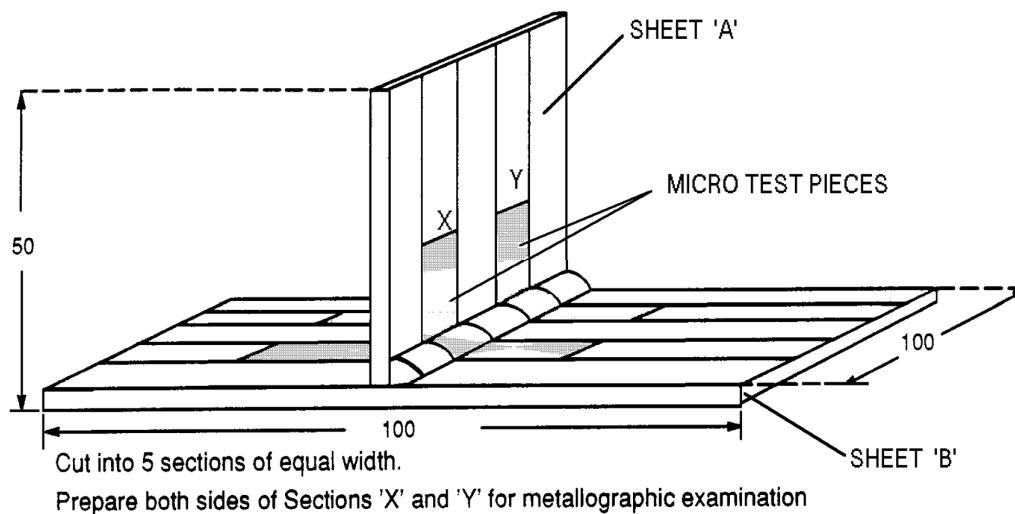

Diagram 3 – Joint No 3 – Sheet to Sheet Fillet Weld

Weld for Aircraft Welding Examination No. 3

- a. For the purpose of undertaking the aircraft welding examination No. 3, a person must carry out two Joint No. 3 - sheet to sheet fillet welds in accordance with the specifications set out in diagram 3.
- b. All measurements are nominal and in millimeters (mm).

A4.11 AIRCRAFT WELDING EXAMINATION NO. 3 – JOINT 3, CONT'D

- c. The examinations must be carried out using parent metals of the same alloy type or grade procured to the applicable specifications referenced in the production procedure/maintenance data.
- d. Examination metal thickness for both arc and gas welding processes are: Sheet "A" - 1.2 mm to 1.3mm (includes 0.50 inch sheet) and Sheet "B" - 1.6 mm (includes 0.063 inch sheet).
- e. If sheets of other thicknesses are used, Sheet B must be two nominal gauge sizes (for the selected material) greater than Sheet A (Note: Authorisation will be subject to thickness conditions).
- f. The plates should be positioned by tack welds on the opposite side to the weld and one weld shall be welded with Sheet 'A' in the vertical (as depicted in Diagram 3).
- g. The second weld shall be with the weld joint in the overhead position.
- h. Completed welds may be cleaned with a wire brush but must not be dressed, hammered or sand-blasted (light tapping with a hammer to remove scale deposits is acceptable and is not regarded as a dressing operation).
- i. Weld residue (flux, slag) shall be removed from the weld in the usual way.

A4.12 AIRCRAFT WELDING EXAMINATION NO. 4 – JOINT 4

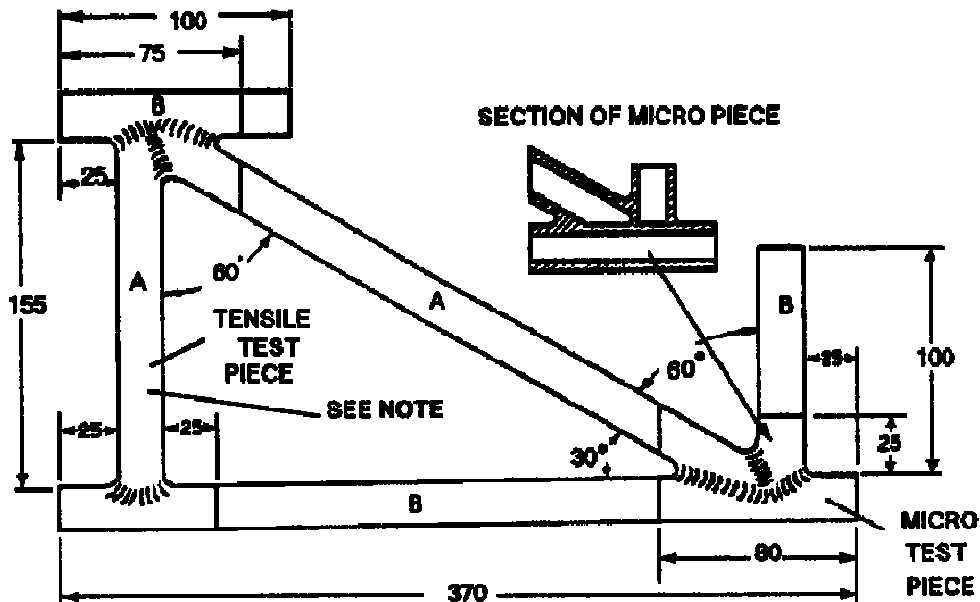

Diagram 4 – Joint No 4 – Tube To Tube Weld

Note: Vent holes should not be drilled in the tensile test piece vertical tube "A".

Weld for Aircraft Welding Examination No. 4

- a. For the purposes of undertaking the aircraft welding examination No. 4, a person must carry out a Joint No. 4 - tube to tube weld in accordance with the specifications set in Diagram No. 4.

A4.12 AIRCRAFT WELDING EXAMINATION NO. 4 – JOINT 4, CONT'D

- b. For the purposes of undertaking the aircraft welding examination No. 4, a person must carry out a Joint No. 4 tube to tube weld in accordance with the specifications set out in Diagram No. 4.
- c. All measurements are nominal and in millimeters (mm).
- d. The examinations must be carried out using parent metals of the same alloy type or grade procured to the applicable specifications referenced in the production procedure/maintenance data.
- e. Each tube has a diameter of 19 mm to 19.5 mm (includes 0.750 inch OD tube). Examination metal thicknesses for oxy-acetylene (gas), GMAW (MIG) and GTAW (TIG) welding processes are: Tubes 'A' - 0.9 mm (includes 0.35 inch) wall thickness and Tubes "B" - 1.4 mm to 1.5 mm (includes 0.58 inch) wall thickness.
- f. For other arc welding processes the examination metal wall thickness is 1.6 mm to 1.65 mm (includes 0.065 inch walled tube) for Tubes "A" and 2.0 mm to 2.15 mm (includes 0.083 inch wall tube) for Tubes "B".
- g. If tubes of other thicknesses are used, then Tubes "B" must be two nominal gauge sizes greater (for the selected material) than Tubes "A". (Note: Authorisation will be subject to thickness conditions).
- h. The tubes shall be prepared assembled (in the manner shown in Diagram No. 4) in a jig and tacked. The assembly is then to be removed from the jig and mounted in a vertical position with the longest tube horizontal and at the lowest point (as depicted in diagram 4). The assembly shall not be moved from this position during the process of completing the welds.
- i. The uppermost joint which is formed by the short horizontal, vertical and diagonal tubes shall be welded by the overhead technique and the remaining joints completed by working around the joints.
- j. Completed welds may be cleaned by wire brush, but must not be dressed, hammered or sand blasted (light tapping with a hammer to remove scale deposits is not regarded as a dressing operation)
- k. Weld residue (flux, slag) shall be removed from the welds in the usual way.

A4.13 AIRCRAFT WELDING EXAMINATION No. 5 – JOINT 5 - PRODUCTION/REPAIR PART WELDS

Weld For Aircraft Welding Examination No. 5

For the purposes of undertaking the aircraft welding examination No. 5; using the procedures, joint configuration, welding positions, equipment and consumables specified for the production or repair weld, a person must carry out a weld on:

- (1) an aircraft part that is no longer intended for use in an aircraft or as a part of an aircraft;
or
- (2) a simulated aircraft part made of a metal of a type and grade that is the same as that metal to be used for the production or repair part.

PART: 2
EXAMINATION ASSESSMENT CONSIDERATIONS

A5.1 ASSESSMENT STANDARD

- a. For the grant, renewal or change of an aircraft welding authorisation an applicant must have passed the aircraft welding examinations considered necessary in the interest of the safety of air navigation. Fundamental to passing an aircraft welding examination is the satisfactory assessment of the completed weld and welded joint.
- b. To ensure standardization assessments of the aircraft welding examinations are to be conducted by an organisation accredited to test metal welds.
- c. Assessment of the weld is to be based on consideration of the entire test sample including visual examination, metallographic examination and mechanical tests where relevant. Where doubt exists as to the acceptability of a sample, or if it is thought that a defect may be of a local nature, further sections should be examined and the assessment of the sample based on all the sections examined. Where a joint sample does not meet the stated criteria in one assessment area, then the complete joint must be repeated and re-assessed.

A5.2 BRAZE WELDING ASSESSMENT

Braze welds must be inspected and tested in accordance with procedures, standards and limitations as set out in an industry standard acceptable to the Authority. Refer to Appendix B of this AC for acceptable standards.

A5.3 FUSION WELDING ASSESSMENT

The assessments required for each aircraft welding examination joint sample are as follows:

- Joint No.1 - Sheet to Sheet Butt Weld: Visual Examination; Bend Test; Tensile Test; and Metallographic Test.
- Joint No.2 - Tube to Sheet Fillet Weld: Visual Examination and Metallographic Test.
- Joint No.3 - Sheet to Sheet Fillet Weld: Visual Examination and Metallographic Test.
- Joint No.4 - Tube to Tube Weld: Visual Examination; Tensile Test and Metallographic Test.
- Joint No.5 - Aircraft Part or Part Typical of Production Weld: Visual Examination and Metallographic Test.

A5.4 VISUAL EXAMINATION

The entire weld is to be examined. Inspection should be performed at magnification of up to three (3) times for welds in parent metal up to 1.6 mm and without magnification for thicker metals.

A5.4.1 Features to be Examined

The contour and weld dimensions should be examined for the following features:

- The transition from the surface of the parent metal to the weld face is to have a reasonably smooth blended contour, free from excessive undercut or an abrupt edge to the re-enforcements at the toe of the weld. Some undercut in parent metal thicknesses of 1.6 mm and above is acceptable where it does not exceed the following amounts, 0.05T or 0.08 mm whichever is the lesser for butt welds and 0.1T or 1.6 mm whichever is the lesser for fillet welds.
- The weld face should be reasonably smooth, free from cavities and other surface defects. The ripple pattern should be regular, and the depth 'B' (Figure 2) of occasional depressions is not to exceed 0.15T, where "T" is the thickness of the thinner parent metal. The weld and adjacent parent metal should be free from excessive weld spatter.
- The weld width "W" (Figures 1 and 2), should be reasonably uniform, and for butt welds the weld width is to be the minimum necessary for the weld metal to penetrate the joint as specified below.
- For butt welds the joint should have complete penetration evidenced by a penetration bead (Figure 1), or the absence of an unfused joint line at the root of the weld (Figure 3).
- Butt weld reinforcement "R" (Figure 1) is to be present and should preferably be approximately 0.3T, but should not exceed 0.5T.
- For external corner welds, the actual throat thickness "A" (Figure 10) is to be not less than "T", weld width 'W' and reinforcement "R" should be the minimum necessary to obtain complete penetration of the joint as evidenced by a penetration bead or the absence of an unfused joint line at the inside corner.
- The presence and extent of warping or misalignment.
- The presence of hard spots or cracking caused by stray arc strikes adjacent to, or on the weld.

A5.4.2 Unacceptable Welds

Welds which exhibit any type of crack, incomplete joint penetration, under-fill or overlap and stray arc strikes made on the parent metal in a position adjacent to or other than the weld preparation are unacceptable.

A5.5 TENSILE TESTS

A5.5.1 Method of Test

The tensile test pieces shown in Joints No. 1 and No. 4, (Diagrams 1 and 4 of Part 1) are to be cut from the sample. Test the piece to destruction in accordance with the specified procedure. Light filing of the internal surface is permitted to obtain a neat fit for this test. The ultimate tensile stress (calculated on the minimum cross-sectional area of the sample neglecting the weld) and the position of the failure should be recorded.

A5.5.2 Tensile Test Assessment

For the Joint No. 1 tensile test, the weld is satisfactory if the test piece fails in the parent metal outside of the heat affected zone as determined by the micro test piece. If failure occurs at the toe of the weld or in the weld metal, the weld is satisfactory only if the fracture surfaces are free of defects (such as cracking, large pores, lack of fusion, excessive porosity or inclusions etc.), and the weld conforms to all other requirements and the ultimate tensile strength (UTS) is at least 90% of the strength of the parent metal. If any doubt exists as to the value of the UTS, it is recommended that a hardness test be conducted to accurately determine the UTS. This may be necessary if the failure in the parent metal occurs at less than 90% of the published UTS value for a given material. The UTS for a given material will have a range of values, if the material falls into the lower range of values, the UTS will also be lower. For the Joint No. 4 tensile test, the test piece must fail in the parent metal, outside of the HAZ as determined by the micro test piece. Failure in any other area is cause for rejection.

A.5.6 BEND TEST

A.5.6.1 Method of Test

The bend test piece is to be cut from the sample and tested with the weld lying along the centerline of the bend with the weld face (the side from which the welding was performed) on the outside of the bend in accordance with the specified procedure. The test piece is to be dressed on both sides e.g., by filing or grinding, so that the weld metal is flush with parent metal. The edges of the test piece should be given a reasonable radius. Bending is to be carried out by the application of continuous pressure.

A.5.6.2 Extent of Bend Tests

The test sample is to withstand bending through an angle of 180° over a radius of twice the nominal thickness, "T", of the test sample without breaking or developing a crack visible to the unaided eye, except for the material listed in the following table and where the material specification for the parent metal specifies a less severe bend.

MATERIAL	ANGLE OF BEND (DEGREES)	RADIUS OF BEND
Magnesium Alloys	180	10T
Aluminum Alloys containing more than 6% Mg	180	5T
Aluminum Alloys of the 6061-6063 Type	180	8T
Cr-Mo Steels of the 4130 Type*	90	4T
Titanium Alloys - Tensile Strength Less than:		
516 Mpa	180	3T
516-827 Mpa	180	5T
827-965 Mpa	180	8T
965-1069 Mpa	180	10T
1069-1171 Mpa	180	14T
Martensitic and PH Stainless	Not Applicable	Not Applicable
Steels and PH Nickel Alloys	Not Applicable	Not Applicable

* After any pre or post-weld heat treatments similar to production welds represented by the test samples.

A.5.7 METALLOGRAPHIC EXAMINATION

A.5.7.1 Method of Test

- a. The metallographic (macro) tests are to be carried out in accordance with the specified procedure. Sections are to be taken from each test sample at the following locations and prepared for metallographic examination as follows:
 - Joints No. 1 to 4: At the approximate locations shown in the relevant joint sketches (Diagrams 1 to 4 of Part 1).
 - Joint No. 5: At appropriate locations to cover each type of joint in the weldment.
- b. An additional sample should be prepared and examined if doubt exists as to the acceptability of the sample. The sections are to be taken transverse to the direction of welding at locations where the weld quality appears poorest, except that the start and finish sections of the sheet samples should be avoided.

A.5.7.2 Weld Assessment Criteria

The sections should be examined un-etched and etched at magnification of up to five (5) times and where appropriate, reported in accordance with the following requirements:

- The depth of fusion of fillet welds "F" (Figures 4 to 7) shall be at least 0.15T, where "T" is the thickness of the thinner parent metal.
- The size of fillet welds "S" (Figures 4 and 5) are to be not less than the following values, where "T" is the thickness of the thinner parent metal:

PARENT METAL THICKNESS (MM)	MINIMUM WELD SIZE
0.254 - 0.635	2.4T
0.660 - 1.270	1.6T
1.295 - 2.285	1.3T
2.310 - 3.175	1.1T
3.200 and over	T

- The design throat thickness of fillet welds "D" (Figure 4) should not be less than 0.7 x the minimum weld size "S" as specified above.
- In fillet welds some lack of complete root fusion is acceptable where the following conditions exist. In all other cases complete root fusion is required.
- For welds of approximately 45⁰ included angle, the unfused distance "X" (Figure 6) should not be greater than 1/3 of the distance "Y".
- For welds of approximately 30⁰ included angle, the presence of a cavity and an unfused section is permissible provided that the throat thickness "D" is not less than the minimum weld size "S" specified above (Figure 7).
- For welds of 90⁰ in sheets or tubes where the base metal thickness is equal to or less than 1.6 mm incomplete root fusion of either weld leg for a distance "X" of not more than 0.3 times actual throat size "D" is acceptable (Figure 8) provided that the actual throat thickness is not less than the minimum weld size "S" specified above.
- For lap welds the actual throat thickness "A" (Figure 9) and the weld size "S" should be not less than "T"; depth of fusion "F" should be not less than 0.15T.

A.5.7.3 Unacceptable Weld Features

Welds which exhibit any of the following defects are unacceptable.

- Cracks.
- Incomplete fusion at the weld face except for the cases stated above.
- Undercut in excess of the amounts stated in the visual examination.
- Overlap.
- In fillet welds a ratio of the leg of the larger size to the leg of the smaller size of greater than 1.5 at any cross section.
- A leg length more than $6T$ or $T + 4.5$ mm whichever is the lesser for fillet welds in parent metal thicknesses equal to or less than 1.6 mm (where members differ in thickness "T" are to be based on the thinner member).
- In convex fillet welds a convexity in excess of 0.1 times the average weld leg length at any location.
- In concave fillet welds, an actual throat size of less than $0.5T$ at any cross section. Where members differ in thickness "T" are to be based on the thinner member.
- Excess penetration at the tube or sheet face opposite the weld bead in fillet welds of more than 1.6 mm thickness. In thickness up to and including 1.6 mm, excess penetration may extend for a distance of not more than the tube or sheet thickness "T" beyond the tube or sheet wall.
- An individual pore size of $0.4T$ or 2.5 mm whichever is the lesser (where members differ in thickness "T" is to be the thickness of the thinner member).
- Excessive porosity. Inclusions such as Tungsten shall be counted as porosity. All defects less than 0.05 mm size in parent metal thicknesses, up to 1.6 mm and less than 0.12 mm or $0.03T$ size, whichever is the lesser in parent metal thicknesses above 1.6 mm, are to be disregarded. Where porosity or the maximum pore size appears excessive, the weld is to be sectioned at other locations or broken open (nick-break) and a length of the weld examined. The assessment is to be based on the weld length of all metallographic sections.
- Any other defects which are attributable to unsatisfactory welding techniques or any unsatisfactory knowledge of welding consumables or the parent metals used.

A5.8 WELD ASSESSMENT – FIGURE: 1

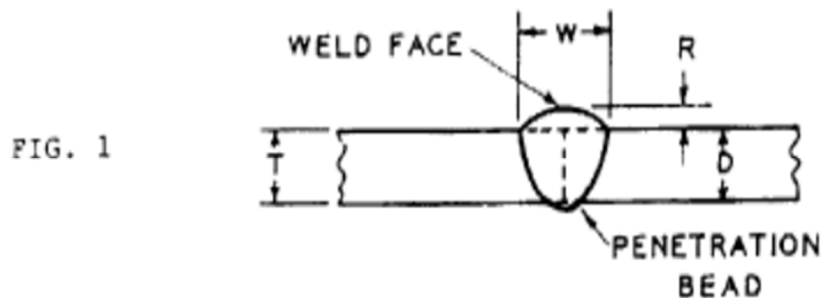

A5.9 WELD ASSESSMENT – FIGURE: 2

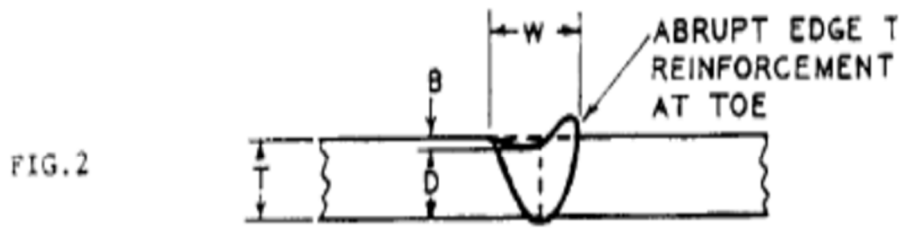

A5.10 WELD ASSESSMENT – FIGURE: 3

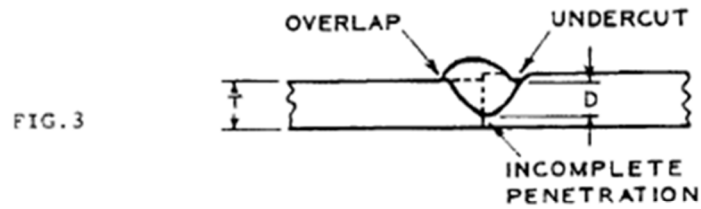

- B = DEPRESSION DEPTH
- D = DESIGN THROAT THICKNESS
- R = REINFORCEMENT
- T = THICKNESS OF THE THINNER PARENT METAL
- W = WELD WIDTH

A5.11 WELD ASSESSMENT – FIGURE: 4

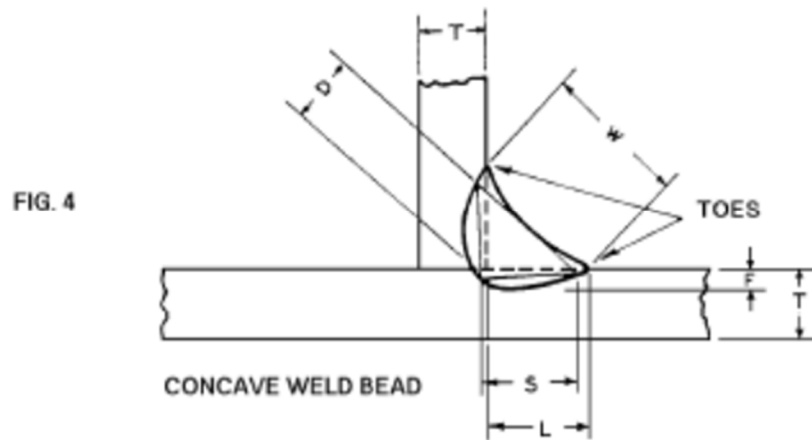

A5.12 WELD ASSESSMENT – FIGURE: 5

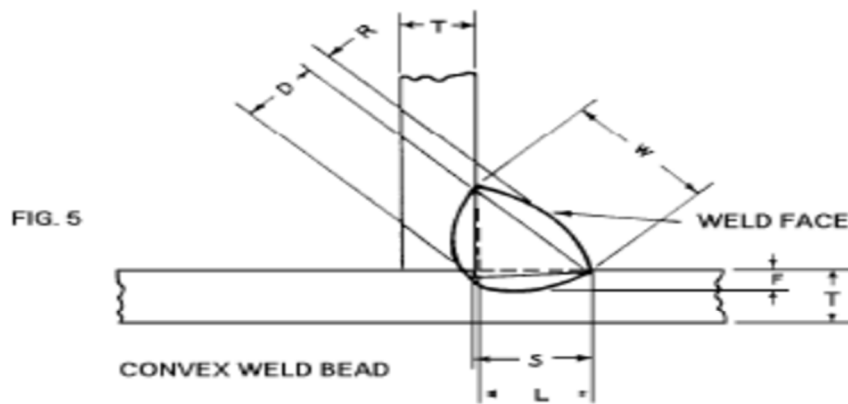

- D = DESIGN THROAT THICKNESS
- F = FUSION DEPTH - MAXIMUM
- L = LEG LENGTH
- R = REINFORCEMENT
- S = SIZE OF WELD
- T = THICKNESS OF THE THINNER PARENT METAL
- W = WELD WIDTH

A5.13 WELD ASSESSMENT – FIGURE: 6

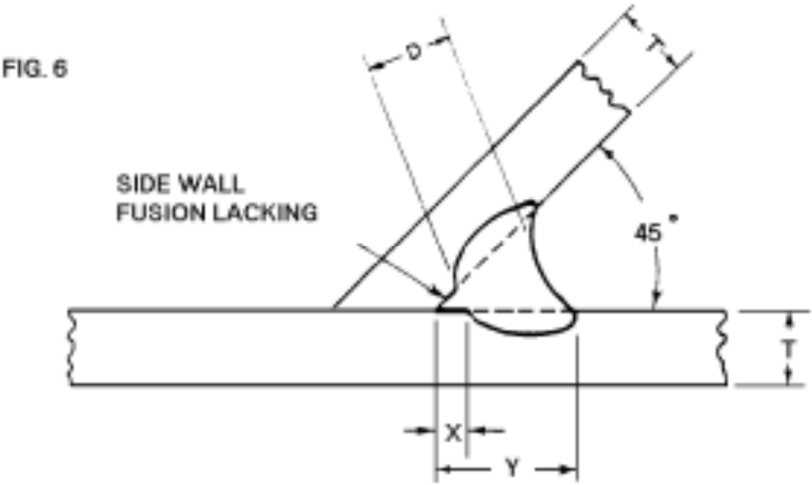

A5.14 WELD ASSESSMENT – FIGURE: 7

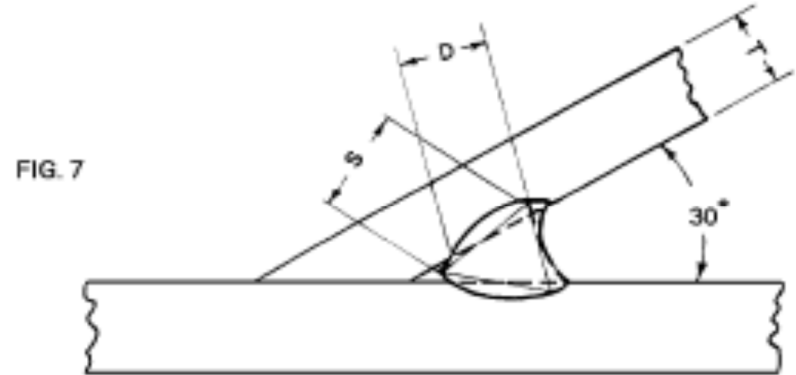

A5.15 WELD ASSESSMENT – FIGURE: 8

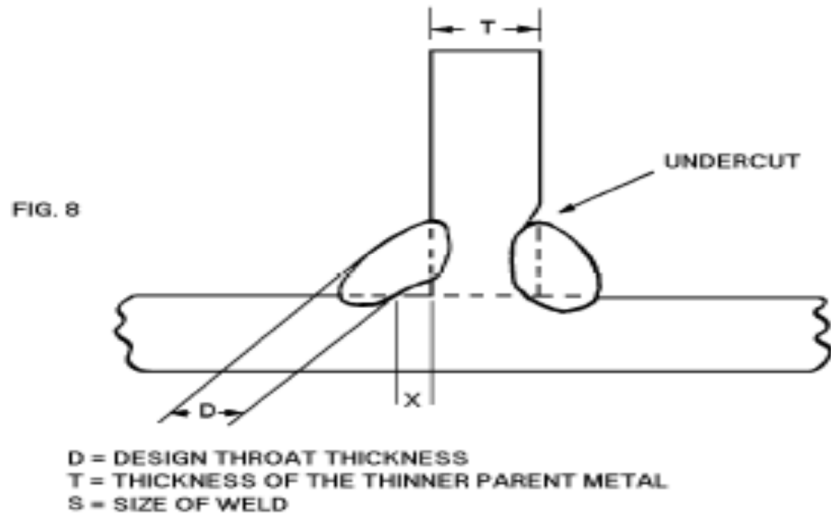

A5.16 WELD ASSESSMENT – FIGURE: 9

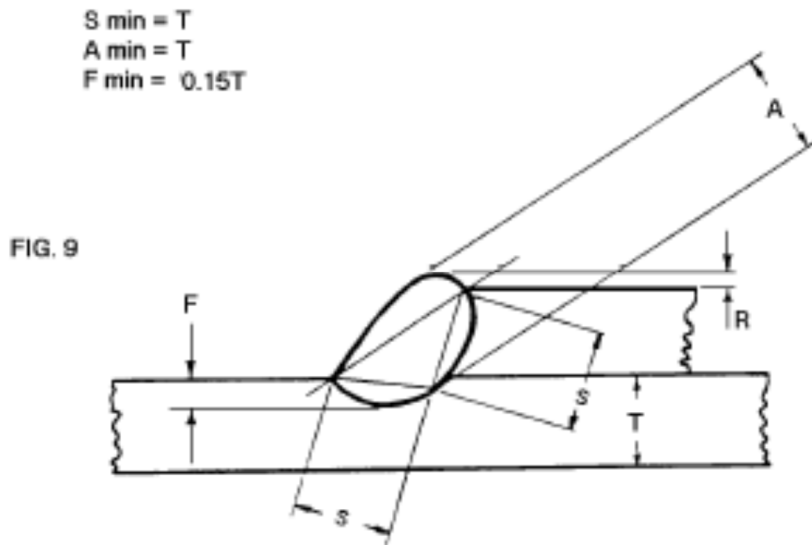

A5.17 WELD ASSESSMENT – FIGURE: 10

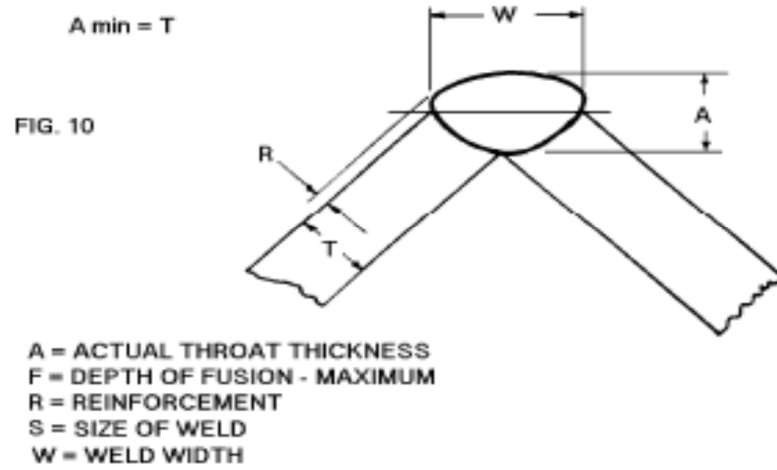

APPENDIX: B

ACCEPTABLE STANDARDS

- B1** AS/NZS 3992 - Welding and brazing qualification.
- B2** AWS B2.1 - Specification for Welding procedure and Performance Qualification.
- B3** AWS B2.2 - Specification for Brazing Procedure and Performance Qualification.
- B4** AWS C3.4 - Specification for Torch Brazing.
- B5** AWS D17.1 - Specification for Fusion Welding for Aerospace Applications.

(INTENTIONALLY LEFT BLANK)